

9. Water

78

9. Water

(1) Water Valves and Meter

In the meter box outside your entranceway, there is a water valve and a water meter.

To commence water use, please turn the valve (counterclockwise to open, clockwise to close).

If water overflows, or when you are going to be out of your apartment for a long time, please close the valve.



valve

water meter

(2) Water Supply Stoppage

If you should have a stoppage in water supply, please close the valve and all other taps.

If you should fail to do this, when the water supply is restored, appliances may overflow and water may leak through to apartments below you.

If you have the end of a drainage hose in the bathtub or other container that has water in it, please remove it in the event of a cut in water supply. Failure to do so can mean that when the water supply is restored, dirty water may get sucked up into the water supply piping.

After a cut in water supply, when opening the valve, you may hear some strange noises. These noises are the result of air having entered the water supply piping, so open all your taps and wait for it to clear.

(3) Accidents with Overflowing Water

In reinforced concrete apartment complexes, the bathroom is the only room that is waterproofed. Please take care to prevent overflows from washing machines, and be careful of water overflowing if you did not close the valve after water a supply stoppage.

Many water leakage troubles have occurred due to carelessness on the resident's side, such as the discharge hose dropping off from the drain outlet, for example. If the water leakage causes any damage to household goods in apartments directly below, the compensation for the damage may be unexpectedly expensive. We recommend you get insurance that supports such water leakage resulting from fault on the resident's side, such as fire insurance for collective housing.

If water should overflow, then close the valve, wipe up the spilled water, and inform the people living below you.

If a broken water supply pipe in your apartment should result in flooding, close the stop valve in the meter box, and contact the Administration Service Office or Residence Center or other management facilities.



(4) Dripping Faucets or Irregular Noise

If a faucet still drips after it is closed tightly, or if it makes strange noises when you turn it on, you have a deteriorated washer.

Please replace the washer quickly, as ignoring this problem will lead to the damage of faucet or water pipes, and will waste water.

To replace the washer, first turn off the valve at the meter box, undo the nut on the top of the faucet, and replace the washer

(see the diagram below). (Please refer to page 78.)

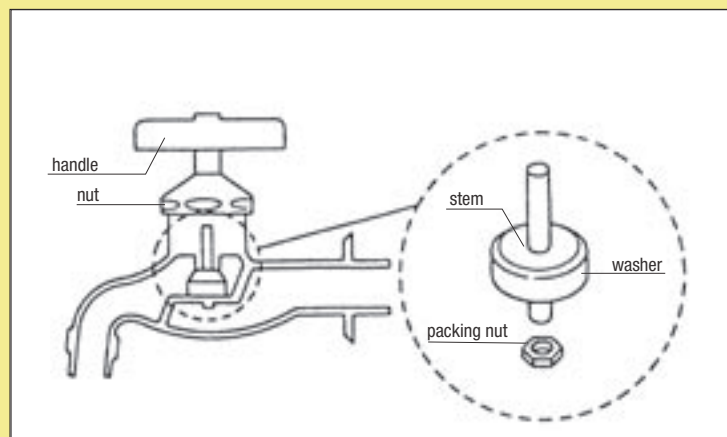

(5) Using Water First Thing in the Morning - Not for Drinking

When running water first thing in the morning, or when you have not run water for a long period of time, such as during holidays, we recommend that as a precautionary measure you use the first bucketful of water for purposes other than drinking.

